

Reprinted from THE REVIEW OF SCIENTIFIC INSTRUMENTS, Vol. 32, No. 8, 885-888, August, 1961
Printed in U. S. A.

Simple Apparatus for the Generation of Pressures above 100 000 Atmospheres Simultaneously with Temperatures above 3000°C

WILLIAM B. DANIELS* AND M. T. JONES†

Research Laboratory of National Carbon Company, Division of Union Carbide Corporation, Parma 30, Ohio

(Received March 30, 1961)

Equipment has been constructed for experimentation at very high pressures and temperatures. With the modified Bridgman anvil device described, it has proven possible to maintain pressures in excess of 100 000 atm simultaneously with temperatures above 3000°C for periods greater than one hour. [The fixed points used to infer this pressure are taken to be the pressure values established by Bridgman for discontinuities of the electrical resistance of bismuth and barium, 25 650 kg cm⁻² and 80 000 kg cm⁻², respectively, and called the bismuth and barium points. Recent unpublished work indicates that the barium point pressure will probably have to be revised downward materially, reducing our pressure estimates in the upper range.] The use of an extrudable plastic compressible gasket is described. Several considerations are presented concerning the support of high pressure components constructed of cemented tungsten carbide. Coesite, almandite, and diamond have been synthesized in the apparatus.

INTRODUCTION

A SIMPLE modified Bridgman anvil device has been constructed using a radially composite compressible gasket geometry. The equipment resembles the Hall "Belt" apparatus described in a recent article¹ but large relative compression of the gasket is achieved in a different manner. The high pressure core of the apparatus which is shown in Figs. 1 and 2, consists of two frusto-conical cemented tungsten carbide rams and a cemented carbide core vessel supported radially by pressed-on alloy steel cylinders. Cemented tungsten carbide with 6% cobalt has been used throughout this work. Pressure is generated by advancing the rams with a hydraulic press, compressing the contents of the core vessel while compressing and extruding the gasket seal. The pressure transmitting medium has been pyrophyllite. Internal heating is provided by passing an electric current via the rams, through a conduction heating tube along the axis of the core vessel.^{1,2} The sample to be investigated lies within the heating tube. Pressure calibration of this system has been made by the standard procedure of observing sharp changes in electrical resist-

ances during polymorphic transitions at fixed pressures with wires of Bi and Ba inside a silver chloride sleeve replacing the testing tube. For the ½-in. bore system, the loads required to reach the Bi I→II transition, taken to be 25 650 kg/cm²,³ and the transition in barium, taken to be 80 000 kg/cm²,³ were 56 tons and 165 tons, respectively, yielding 100 000 kg/cm² at about 205 tons. Temperatures

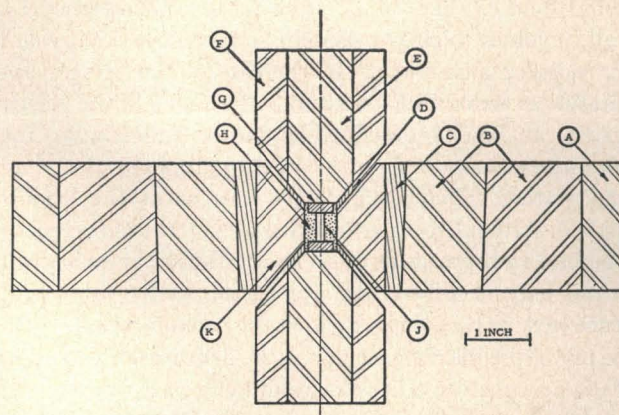

FIG. 1. Cross section of modified Bridgman anvil device. (A) safety ring, (B) binding rings, (C) shim, (D) Teflon compressible gasket, (E) cemented tungsten carbide ram, (F) ram support, (G) steel decompression cap, (H) pyrophyllite pressure transmitting cylinder, (K) cemented tungsten carbide die, and (J) sample container and heating tube.

³ P. W. Bridgman, Proc. Am. Acad. Arts Sci. 81, 165 (1952).

* Presently a member of the faculty of the Mechanical Engineering Department of Princeton University, Princeton, New Jersey.

† Presently a member of the research staff of the Lubrizol Corporation, Cleveland, Ohio.

¹ H. Tracy Hall, Rev. Sci. Instr. 31, 125 (1959).

² R. Roy and O. F. Tuttle, J. Phys. Chem. Earth 1, 138 (1956). Describes Loring Coe's internally heated apparatus.

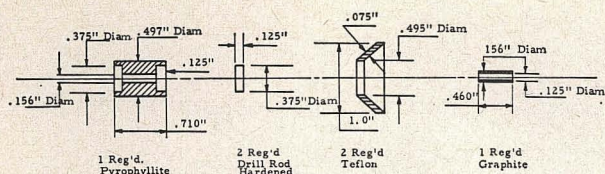

FIG. 2. Dimensions of sample cell parts.

have been estimated from power consumption, using the melting temperature of nickel as the upper calibration point. The apparatus has been operated without failure for periods over one hour at a pressure of 100 000 kg/cm² simultaneously with temperatures above 3000°C, by applying coolant to the support rings.

Perhaps the most outstanding characteristic of successful equipment designed to reach very high pressures and temperatures is that of apparent simplicity, exemplified by the Bridgman anvil³ and its modifications. However, success or failure is often contingent on details of construction, such as a few degrees of angle, choice of a correct grade of steel or a fraction of a percent of interference in a set of supporting members, to mention but a few critical items. Part of the fascination of high pressure research is associated with finding solutions to such problems. Details of the present apparatus will be presented under four headings: (1) the compressible gasket and its geometry, (2) decompression caps, (3) stressed core components, and (4) binding rings.⁴

COMPRESSIBLE GASKET

Probably the principal difficulty associated with the compressible gasket geometry is that of obtaining sufficient relative motion of the compressing parts if a large sample volume is desired. Hall has solved this by using a three-dimensional compression with multiple anvils in his tetrahedral device.⁵ The "Belt" apparatus,¹ also designed by Hall, involves thick pyrophyllite and steel gasketing and an "angular advantage." In the case of the present apparatus, as shown in Figs. 1 and 2, the action of the plastic gasket can best be described as one of consolidating the otherwise unsupported portion of the pyrophyllite pressure transmitting cylinder during its collapse as the load is applied. Without the consolidation gasket, the pyrophyllite crumbles and spreads out into a very thin layer which will permit only very little relative motion of the rams, and hence very little compression of the sample region. With the use of the plastic gasket, only a slight lateral extrusion of the pyrophyllite takes place and by proper choice of the overlength of the pressure transmitting cylinder, a thick, easily compressible gasket of pyrophyllite forms during the early stages of the compression. A pyrophyllite cylinder

⁴ Dr. Jones contributed the tapered ram design and binding ring design reported in this paper. Subsequent studies and developments here reported are the work of Dr. Daniels.

⁵ H. Tracy Hall, *Rev. Sci. Instr.* **29**, 267 (1958).

0.710 in. in length has been satisfactory (but perhaps not optimum) on a vessel with a bore $\frac{1}{2}$ -in. in diameter and $\frac{1}{2}$ -in. long.

In the present apparatus, the plastic gaskets reduced the press load necessary to reach the Bi I→II transition from 110 tons to less than 65 tons. (A further reduction was effected by the decompression caps to be discussed.) In many hours of operation at 100 000 atm and 3000°C, no gasket blowouts have occurred. A set of trials using steel rams and dies made with the core half-angle θ taking values between 25 and 55°, showed less than a 10% variation in the press load required to reach the Bi I→II transition indicating that using the present plastic gasketing, the system is not especially sensitive to the angle for pressures over the 25 000 atm range at least. The set in use at present has a cone half-angle 40°. The materials used as consolidation gaskets have been Teflon or polyethylene. Nylon, Plexiglas, and phenol-formaldehyde resin have been found unsuitable as gaskets because they do not extrude. They have been found to compress initially, then to rupture with explosive violence when the load reaches a critical value. Extrusion of the Teflon or polyethylene yields a desirable graded pressure distribution along the cone elements, helping support the rams and providing axial clamping of the die. Also, with the use of a vertically acting press, the locating and orienting effect of the gaskets makes any auxiliary guidance for the die and its support rings unnecessary, considerably simplifying operation of the unit.

Since Lloyd, *et al.*⁶ report difficulties with pyrophyllite gasket extrusion on their tetrahedral anvil device, it is probable that using extrudable plastic consolidation gaskets along the edges of the pyrophyllite tetrahedron could be advantageous on such devices.

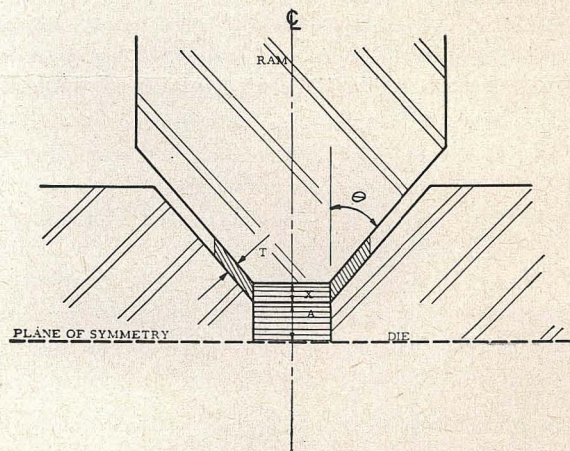

FIG. 3. Core of modified Bridgman anvil device showing critical parameters.

⁶ E. C. Lloyd, U. O. Hutton, and D. P. Johnson, *J. Research Natl. Bur. Standards* **63C**, 59 (1959).

DECOMPRESSION CAPS

The function of decompression caps, which are disks of hardened steel inserted into the pressure transmitting medium, may be seen from the following, referring to Figs. 1 and 3. Consider the consequences of advancing a ram through the small distance δx . If there is no extrusion of the gaskets and the shear strength of the pressure transmitting material is small compared to the average pressures generated, there will be a pressure rise in the sample region $\delta P_1 \approx B_1(\delta x)/(x+a)$ and a pressure rise in the gasket $\delta P_2 \approx B_2(\delta t/t)$. B_1 and B_2 are values of the average bulk moduli of the sample region and the gasket, respectively; a is the axial half-length of the cylindrical hole in the die and t is the thickness of the gasket. If $\delta P_1 \gg \delta P_2$, the gasket will not contain the high pressure sample region but will be blown out or extruded at sufficiently high pressure and if the situation $\delta P_1 \ll \delta P_2$ obtains, the stresses on the components will be unnecessarily large and lead to their premature failure. Thus, the situation $\delta P_1 \approx \delta P_2$ is the most desirable. Assume now that both the sample region and gasket have the same average bulk moduli. Letting $\delta P_1 = \delta P_2$, since $t = x \sin \theta$, $\delta t = \delta x \sin \theta$, we have $\delta x/(x+a) = \delta x/x$ which can be achieved only for the condition $a=0$, i.e., for a "folded" gasket simple Bridgman anvil. In practice, extrusion of the gasket improves the situation, reducing δP_2 . The purpose of the decompression caps, which are relatively incompressible material such as steel, is to increase the average bulk modulus of the sample region relative to the gasket in order to increase δP_1 relative to δP_2 . Their use reduces the press load required to reach the Bi I \rightarrow II transition by about 25%. In addition, if one is using internal electrical heating, the caps distribute the the current over a larger ram area, reducing probability of local overheating and consequent fracture. We have used as decompression caps disks sliced off from a drill rod of appropriate diameter and heat-treated by quenching in a brine bath from red heat. The caps are invariably found to be cracked after a run, but they do not shatter or flow. The absence of nonmetallic thermal insulation between the

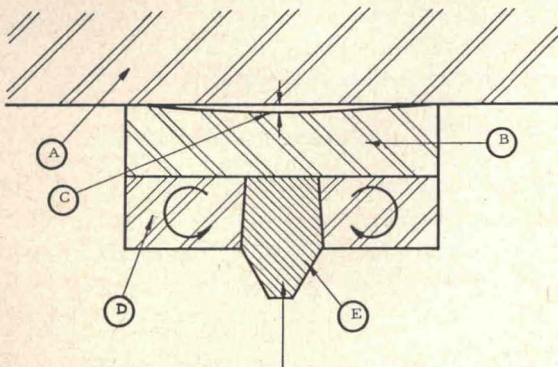

FIG. 4. Proposed variable support scheme for rams. (A) press platen, (B) "saucer backed" backup block, (C) initial gap, (D) ram support ring, and (E) tungsten carbide ram.

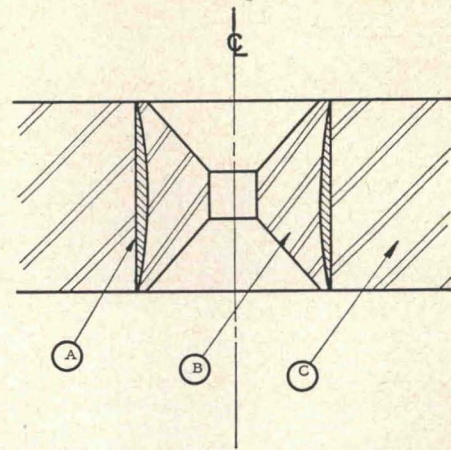

FIG. 5. Hyperboloidal prestressed shape of die. The radial dimensions are shown exaggerated. (A) 0.003-in. thick steel strip between die and binding rings, (B) die, and (C) binding ring set.

high temperature zone and the ram ends does not appear to lead to early failure of the ram. We believe that the axial temperature gradient along the ram may even increase the ram lifetime by reducing the tendency of the material of the small highly loaded ram end to intrude into the main ram body, an effect believed by Bridgman^{3,7} to cause the radial crack failure of his anvils.

STRESSED CORE COMPONENTS

The "geometrical advantage" principle discussed by Hall⁵ is seen to be operative for both the rams and the die. The rams have the highest stresses acting only on the center portions of the diameter. The shrunk-on hardened steel ring provides lateral support for the cylindrical part of the rams. The ram support rings shown in Fig. 1 provide insufficient support with 0.004 in. initial interference on the 1-in. diam. Ram failure occurs at about 130 000 atm at room temperature with the presently used rings, fracture occurring by the characteristic intrusion mechanism described by Bridgman.^{3,7} We propose to try out an improved method of supporting the rams, by which an important part of the radial support will vary monotonically with the axial load applied. The method of accomplishing this is indicated in Fig. 4. The "saucer backed" backup block will deform as the ram load is increased, attempting to force the ring elements to rotate in the direction of the arrows. This rotation must be opposed by a shift of the radial stress S , increasing S near the region a , at the expense of the stress at b . This redistributed stress should reduce ram failure by inhibiting the intrusion of the ram end into the ram body or, one might say, by making the stresses in the critical region more nearly hydrostatic. A geometrical advantage is expected to be gained in the steel support ring since it would be called upon to provide maximum radial

⁷ P. W. Bridgman, J. Appl. Phys. 12, 466 (1951).

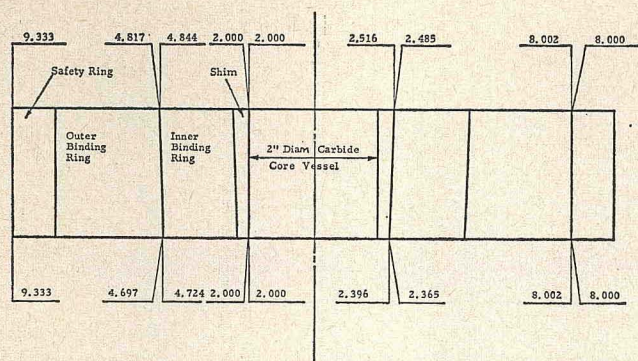

FIG. 6. Cross section of binding ring set giving diametral dimensions. The rings are assembled from the outside to inside. The 2.485-in./2.365-in. surface is finished after B-C-D are pressed in place. The shim ring is split axially into four pieces for ease of removal of broken dies. Small adjustments in the interference of the core in the rings may be made with thin steel shim stock wrapped around the core vessel.

support effectively only along a fraction of its axial length. "Pinch off" of the ram by excessive initial radial stress is avoided. The problem of sliding friction occurring in most variable support systems is not present because all changes in stress would be a result of elastic deformation of the components. Probably the advantage to be gained by this variable support approach will be more readily applied to the simple anvil devices which have a flatter conical portion than do our rams, or to multiple anvil devices.

An additional support to the ram is provided by the extrudable gasket which establishes some pressure gradient along the conical elements giving a "multistaging" effect and avoiding a sharp stress discontinuity.

In the case of the die, the geometrical advantage is gained by permitting only the central part of its axial length to be stressed by the internal pressure. This reduces the net splitting forces, but at the same time, sets up an additional stress system whose effects can be described as forcing elements parallel to the cylindrical external surface of the die into a barrel shaped configuration. This hypothesis is confirmed by the mode of failure of the dies. Cracks perpendicular to the axis of the die begin on the *outer circumference* near its middle and ultimately result in its failure. Axial clamping applied near the die circumference, although it reduces the tendency of this failure to occur, requires additional mechanical equipment. The clamping provided by the compressed gasket, in contrast, aggravates the barreling condition. Our approach to this problem has been to use noncylindrical radial support shown in much exaggerated form on Fig. 5. This could be accomplished by a precision grinding operation on the shim ring or by wrapping a smooth bevel-edged piece of thin steel stock around the middle of the die. We have chosen the latter approach. Note that the initial noncylindrical support stresses put a compressive stress along the external cylindrical elements, and a tensile stress along the internal

elements which must result in a limit to the amount of noncylindrical support it is possible to use. The axial stresses due to the compressed gasket are now applied advantageously to the support of the die, opposing the axial tensions near the core.

In summary, this modification to the usual support has made the stresses in the critical core region more nearly hydrostatic when the system is at high pressure. The advantage of these simple modifications is that the cemented tungsten carbide structure need not be as massive as otherwise would be the case, giving correspondingly lower costs of constructing the high pressure equipment, an important advantage for small laboratory or production work. An additional advantage gained by this support modification is that for a given set of binding rings, one is allowed higher maximum radial support stresses on the center of the die than otherwise would be possible, i.e., the geometrical advantage principle is operating for the *binding rings* because they are forced to provide maximum supporting stress along only a short portion of their axial length.

BINDING RINGS

The dimensions of the binding rings used are shown in Fig. 6. The rings have been assembled from the outside in. The material of the rings is Nationalloy No. 7 gun steel⁸ made up as pancake forgings and heat-treated to a hardness 48/52 Rockwell "C". The safety ring is left annealed. It is believed that the pancake forging leaves a desirable crystallite texture. The shim is made of Neor⁹ hardened and drawn to 60/63 Rockwell "C" then "Electrolized"¹⁰ on its external conical surface to reduce the frictional forces present during assembly. Finely ground molybdenum disulfide was used as a lubricant in all assembly operations. The 0.003-in. thick bevel-edged steel shim used to provide the deviations from cylindrical support, shown in Fig. 5, provides an interference in addition to those shown on Fig. 6. There have been no binding ring failures with the above conditions.

The apparatus is being used at present to study high pressure-high temperature reactions. Several mineral syntheses have been successfully completed at present, among them coesite, almandite, and diamond.

ACKNOWLEDGMENTS

The authors would like to thank Mr. Alfred C. Hoehn for his cooperation in the design of the equipment, Mr. John Benz for making the sample cells, and especially Dr. William J. Spry for his encouragement as group leader of this project.

⁸National Forge, Irvine, Pennsylvania.

⁹Darwin and Milner, Inc., Cleveland, Ohio.

¹⁰Electrolizing Corporation of America, 1650 Collamer Road, Cleveland 10, Ohio.

PRINCETON UNIVERSITY
SCHOOL OF ENGINEERING
PRINCETON, NEW JERSEY

Dear Tracy;

Enclosed please find 3 copies of "Single apparatus" as you requested. I hope you may find something of use in them. The plastic outer support gasketing ought to have an effect for the tetrahedral anvil, permitting a larger fractional overlength of the sample tetrahedron than would otherwise be possible.

As you note by the address, Ursin Carls and I have parted. You certainly were correct in your analysis of companies. It's great to be (more or less) ones own boss. I'm continuing with acoustic and optical studies to 10 K b, and hope to go to a low temperature gas apparatus soon.

Please if you are in the east, look us up and stay over with us. If I get to the west again I'd be quite happy to talk about the work I'm doing at one of your colloquia.

Regards

Bill